

# 混合式步进电动机 HYBRID STEPPER MOTOR

## TYPE 20HS30-0604A035-N75

技术参数 SPECIFICATIONS				接线图 diagram
步距角 step angle	1.8° ±5%	电流/相 current	0.6A	
相数 phase No.	2	电阻/相 resistance	6.5 ±10% Ω	
绝缘电阻 insulation resistance	100MΩ(500V DC)	电感/相 inductance	1.7 ±20% mH	
绝缘等级 insulation class	B	最大静转矩 holding torque	0.18kg. cm	

### 备注 Remarks

1、电机无需配线

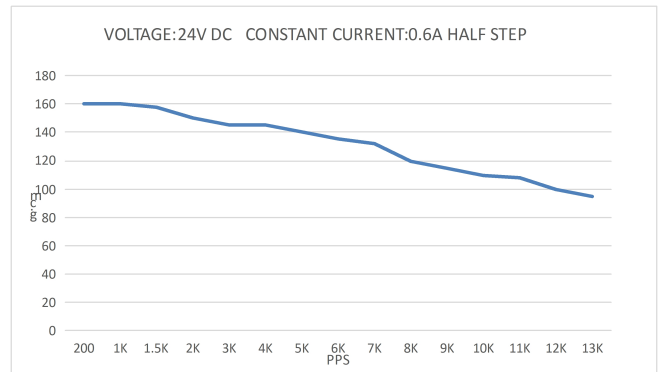
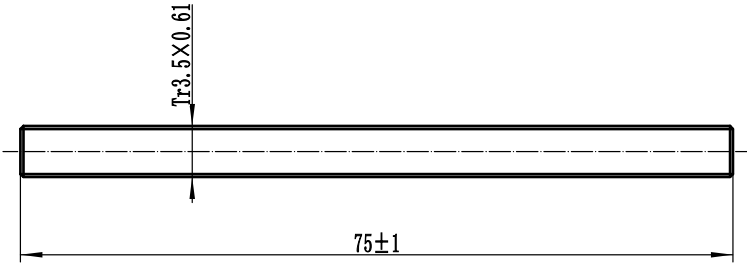

### 外形图 dimensions 单位 unit:mm

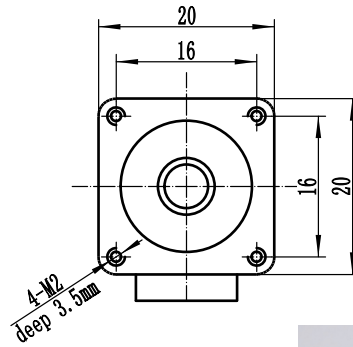
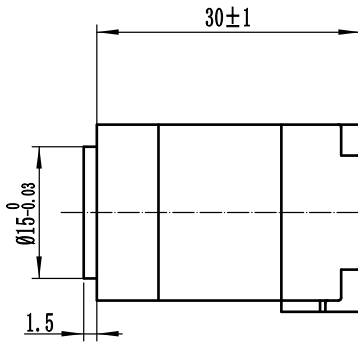

设计 Design	日期 Date	审核 Check	日期 Date	批准 Approve	日期 Date
--------------	------------	-------------	------------	---------------	------------

Changzhou Dewo Motor Co., Ltd  
info@dewochina.com